

DELOMRÅDE 1, Norra delen

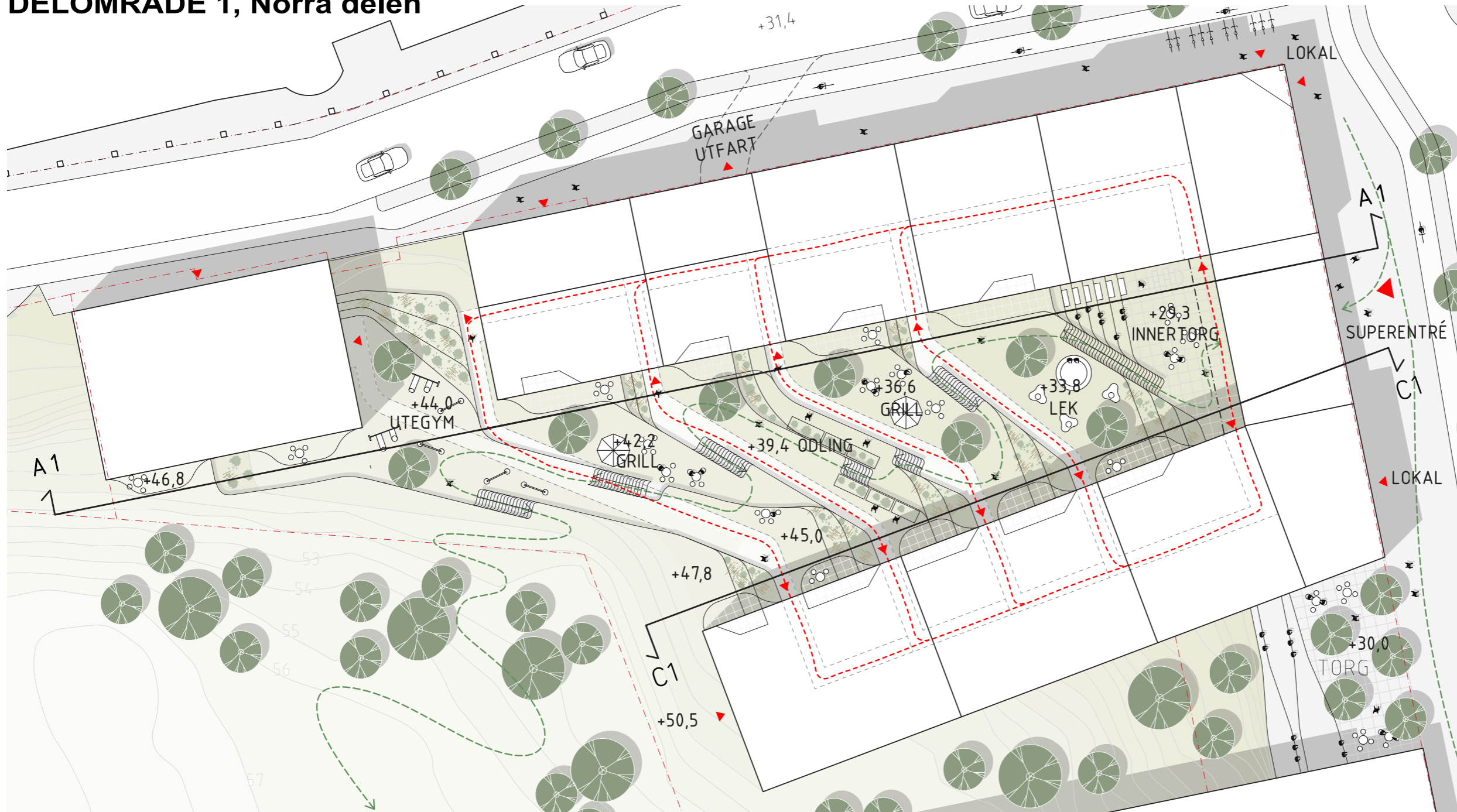

SITUATIONSPLAN

SKALA 1:400

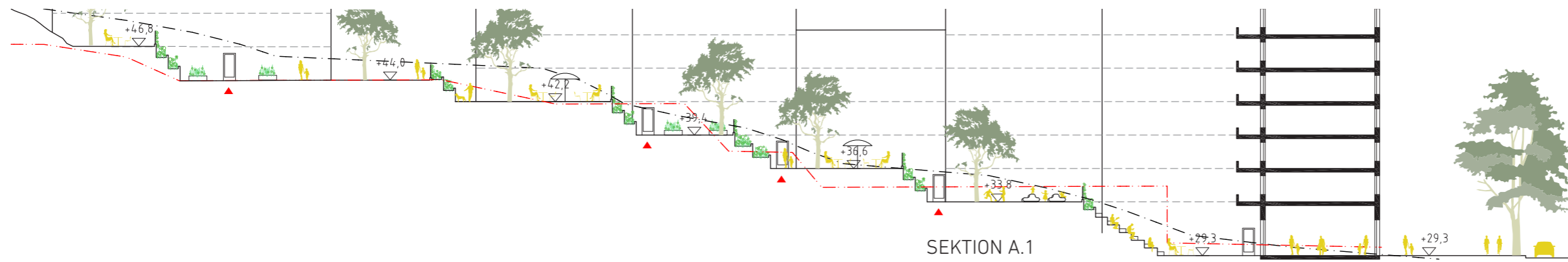

SEKTION A.1

SEKTION A.1

SKALA 1:400

Sektion tagen 1m utanför fasadlivet.

----- Bef. marklinje

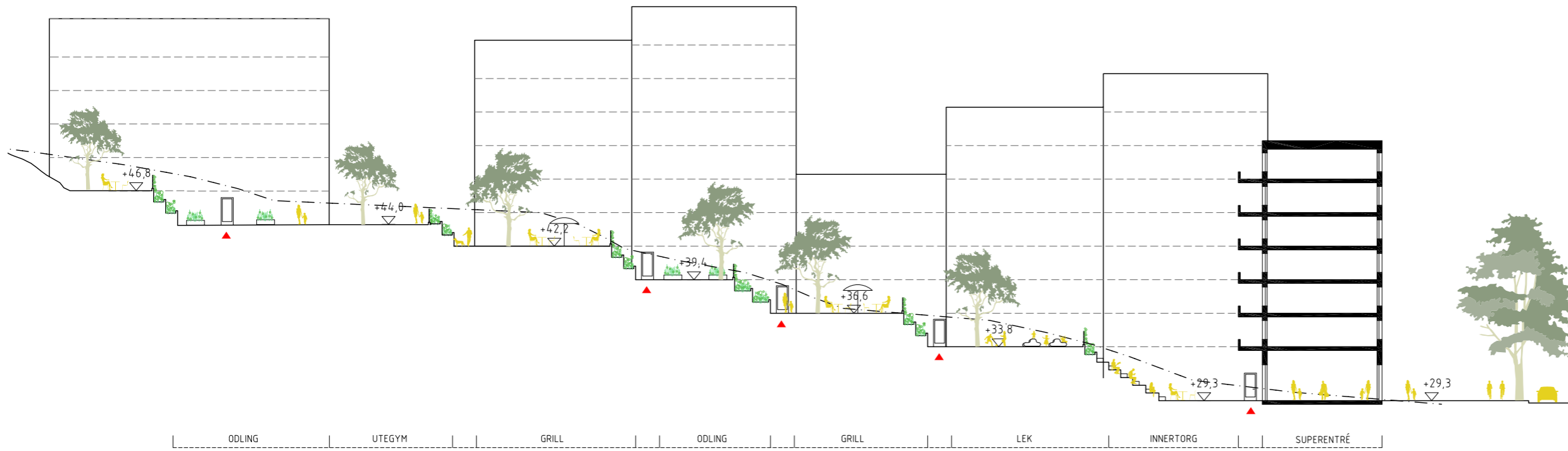

SEKTION A.1

SEKTION C.1

SKALA 1:400

Sektion tagen 1m utanför fasadlivet.

----- Bef. marklinje

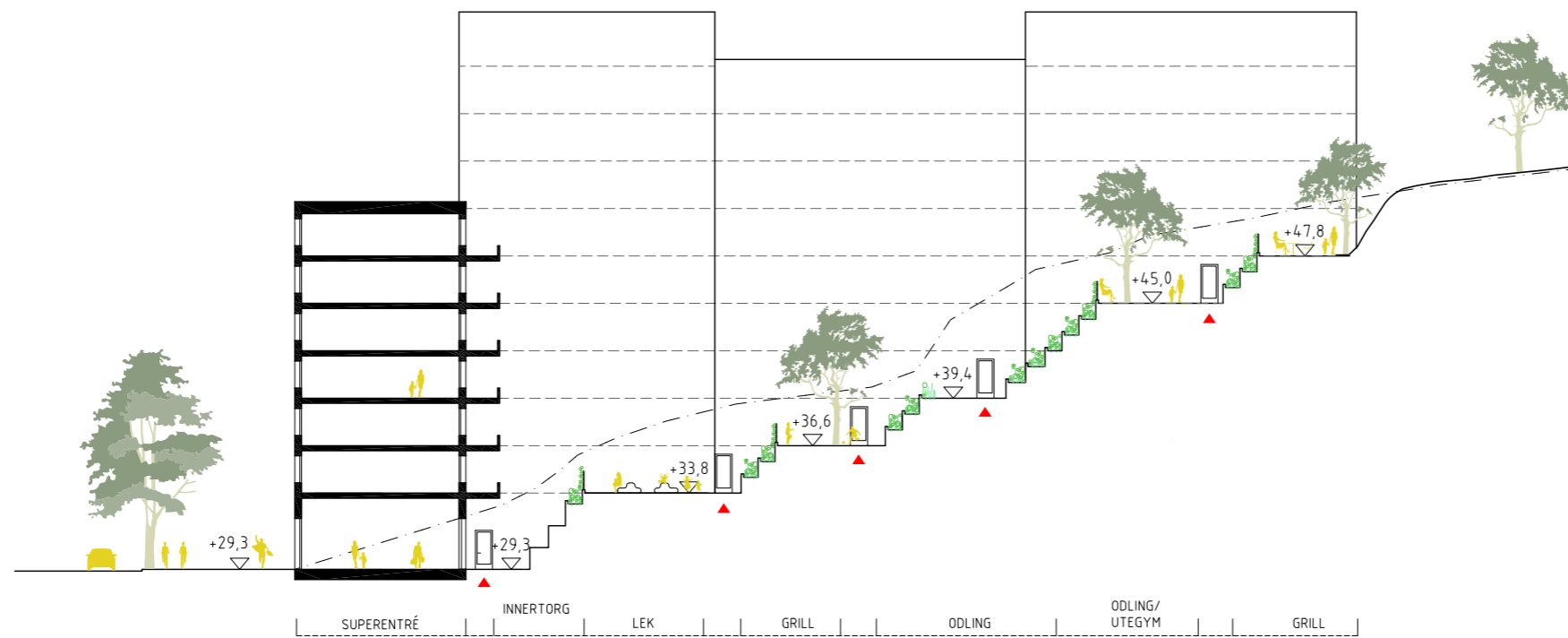

SEKTION C.1

DELOMRÅDE 1, södra delen

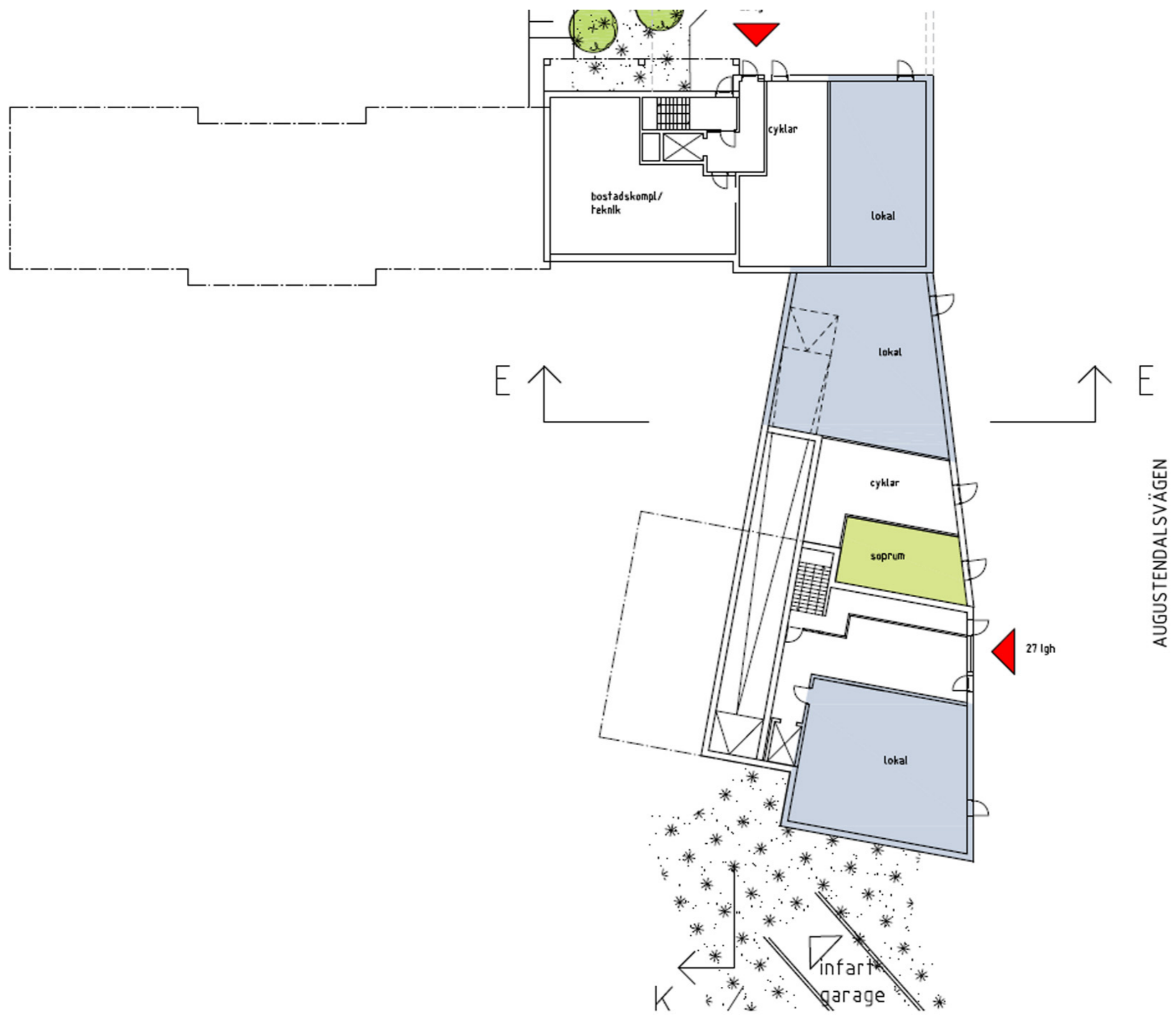

DELOMRÅDE 1

SEKTIONER

SEKTION E-E

1:400

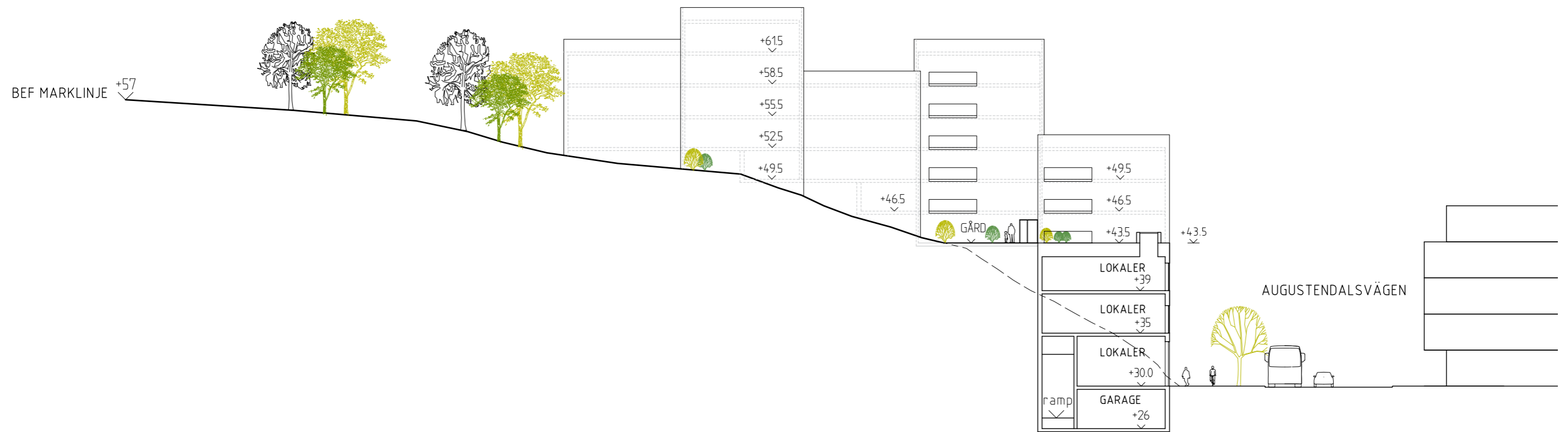

FÖR FASADILLUSTRATION SE S.27

DELOMRÅDE 2

FASAD MOT SÖDER

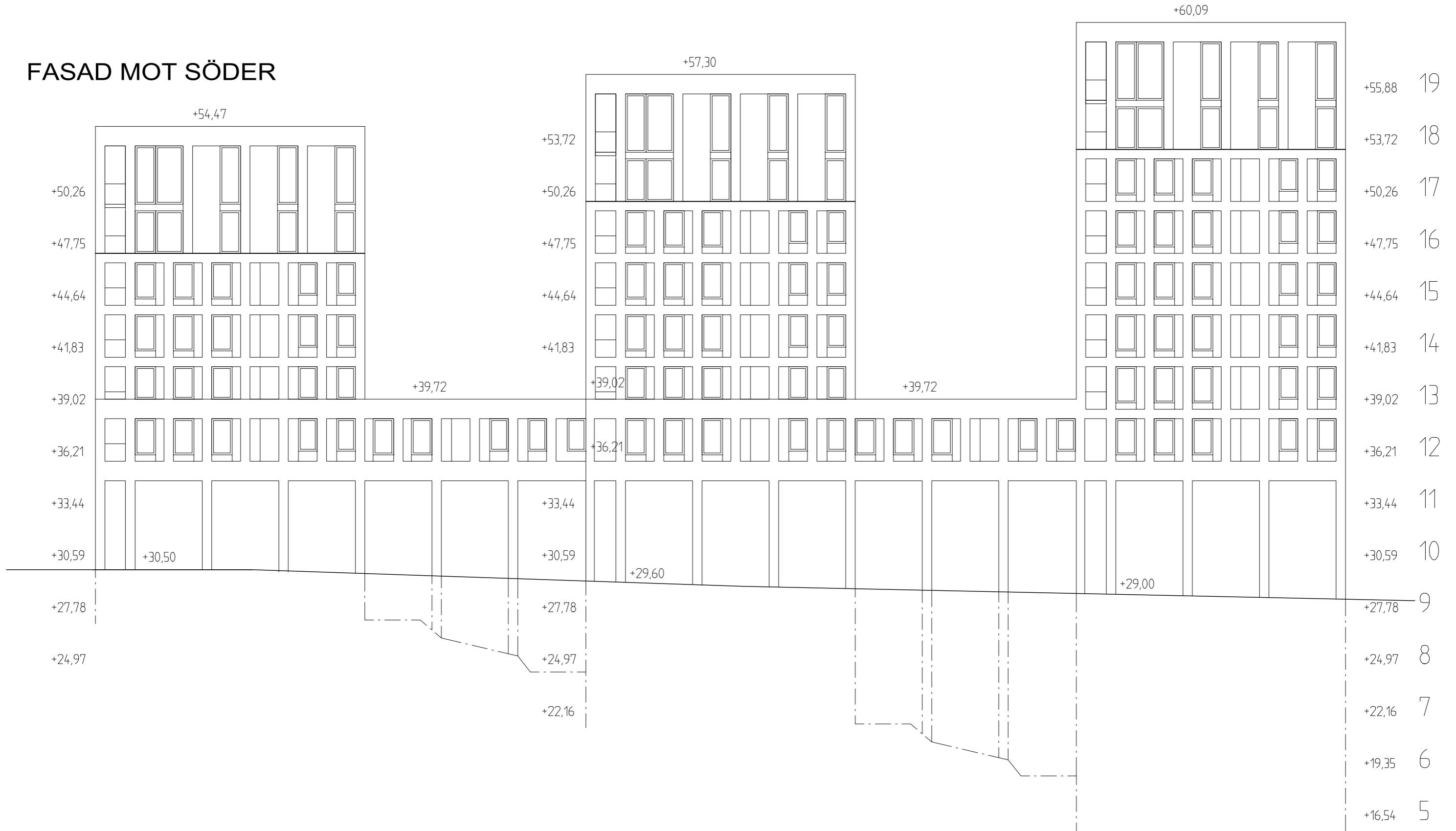

Nacka Strand hus 14
Carlyle Group
2015-06-26
Sydfasad
Skala 1:200

0 2 4 6m

Joliark

DELOMRÅDE 2

FASAD MOT SYDVÄST

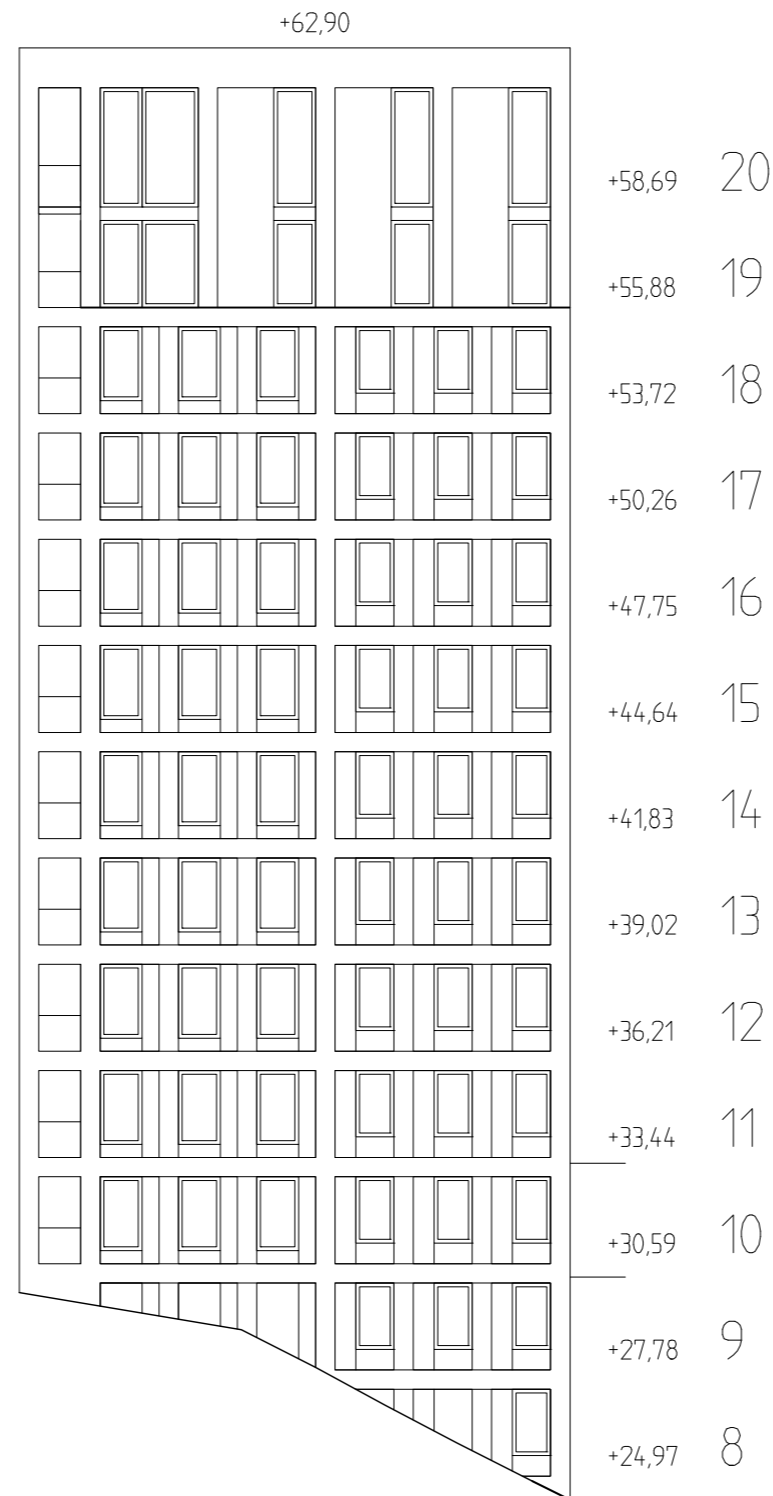

Nacka Strand hus 14
Carlyle Group
2015-06-26
Sydvästfasad
Skala 1:200

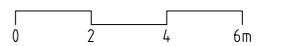

Joliark

DELOMRÅDE 2

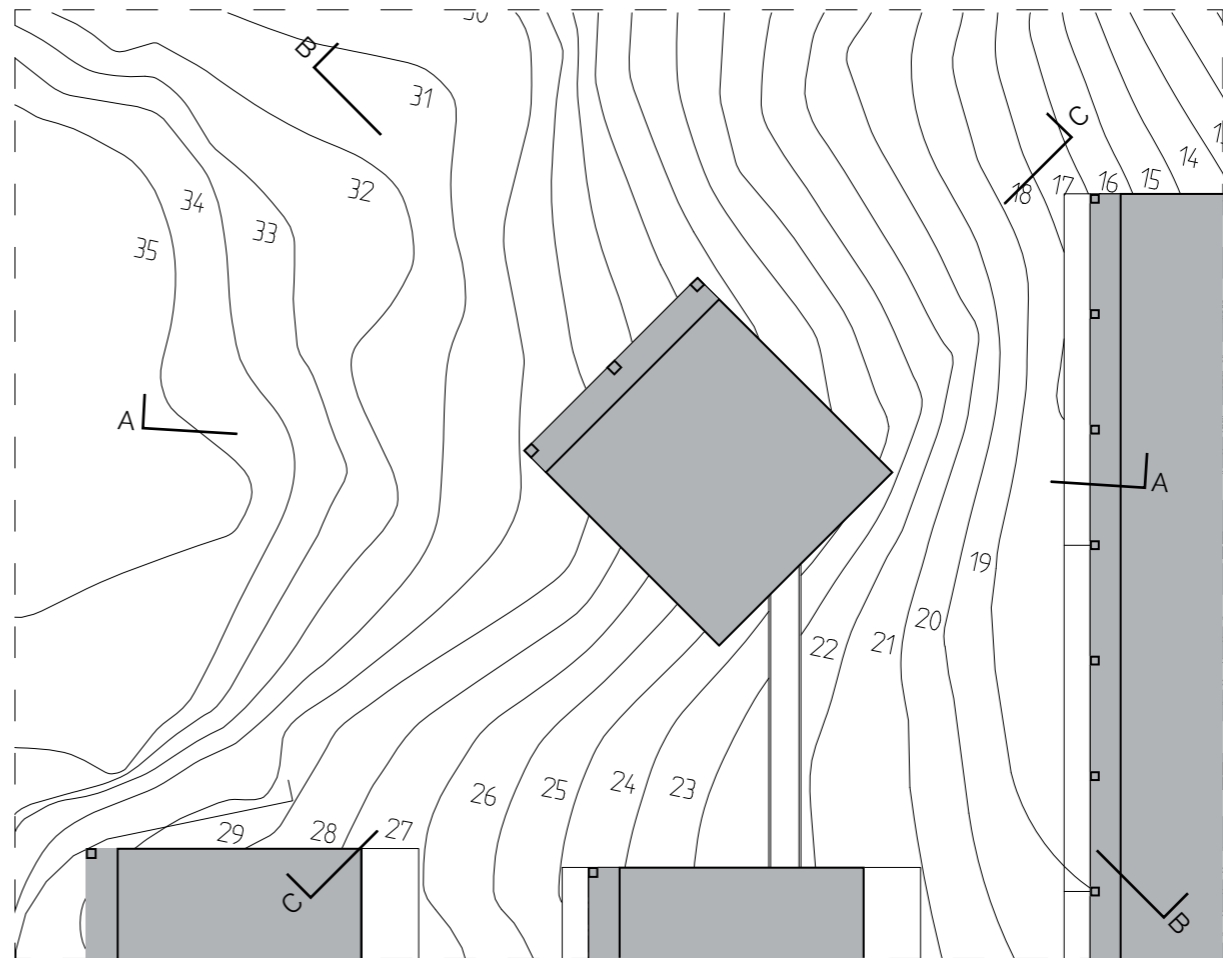
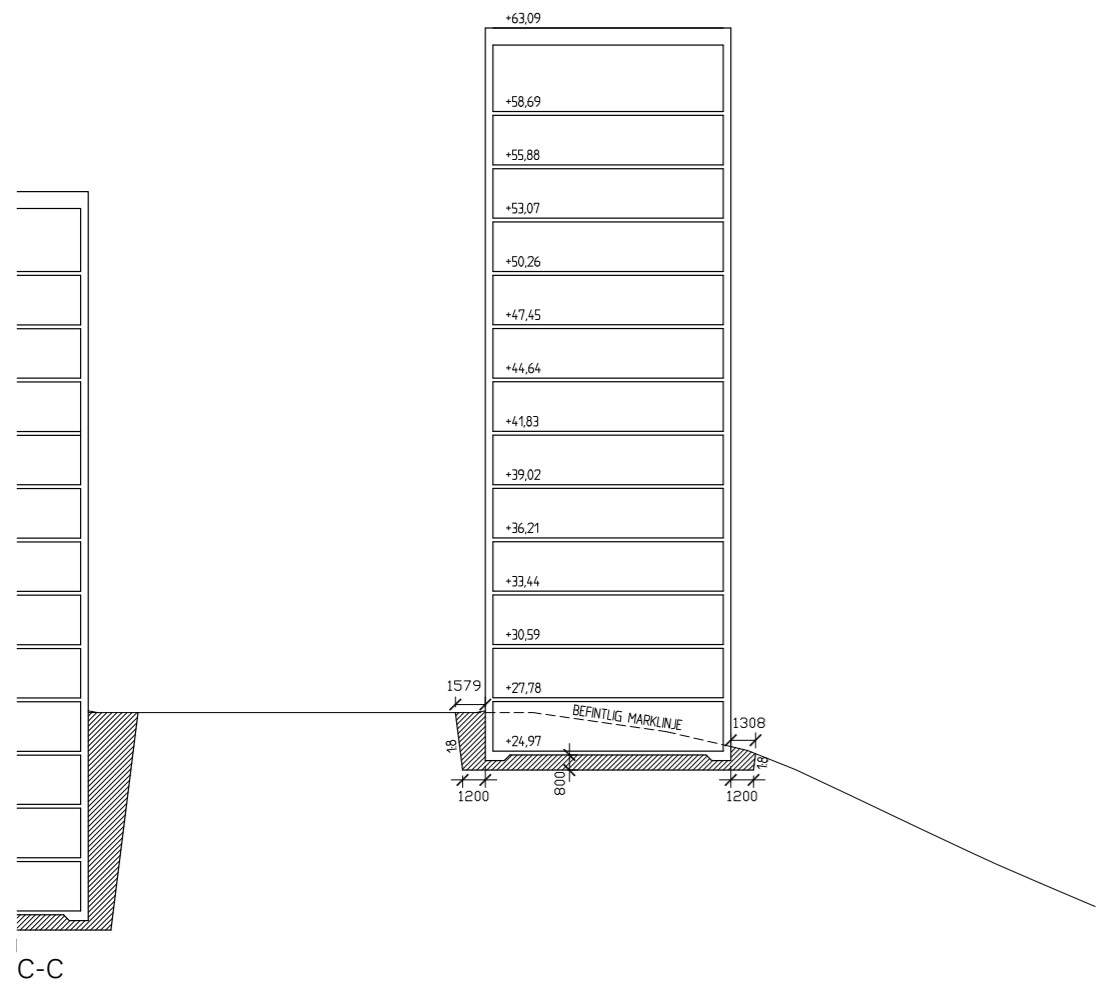
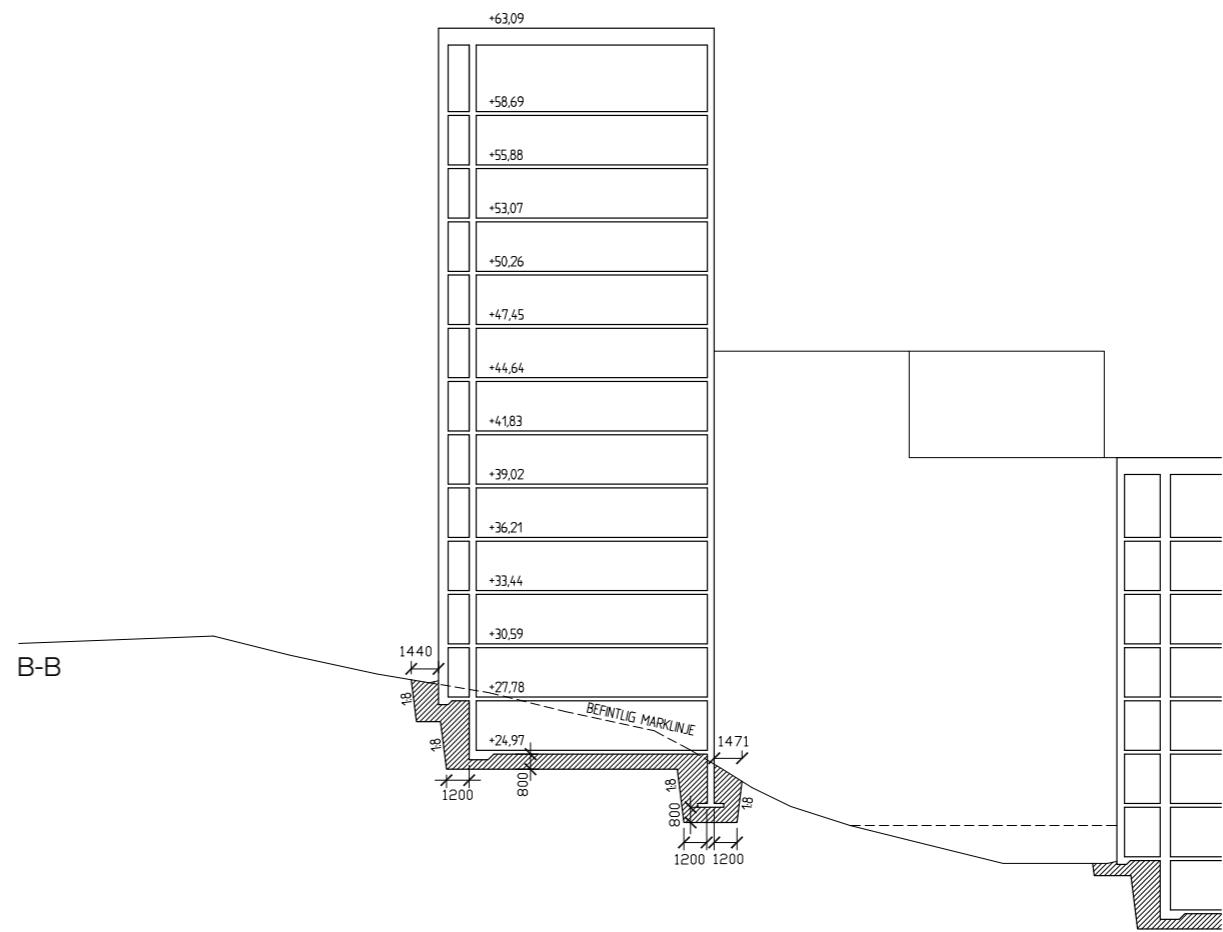
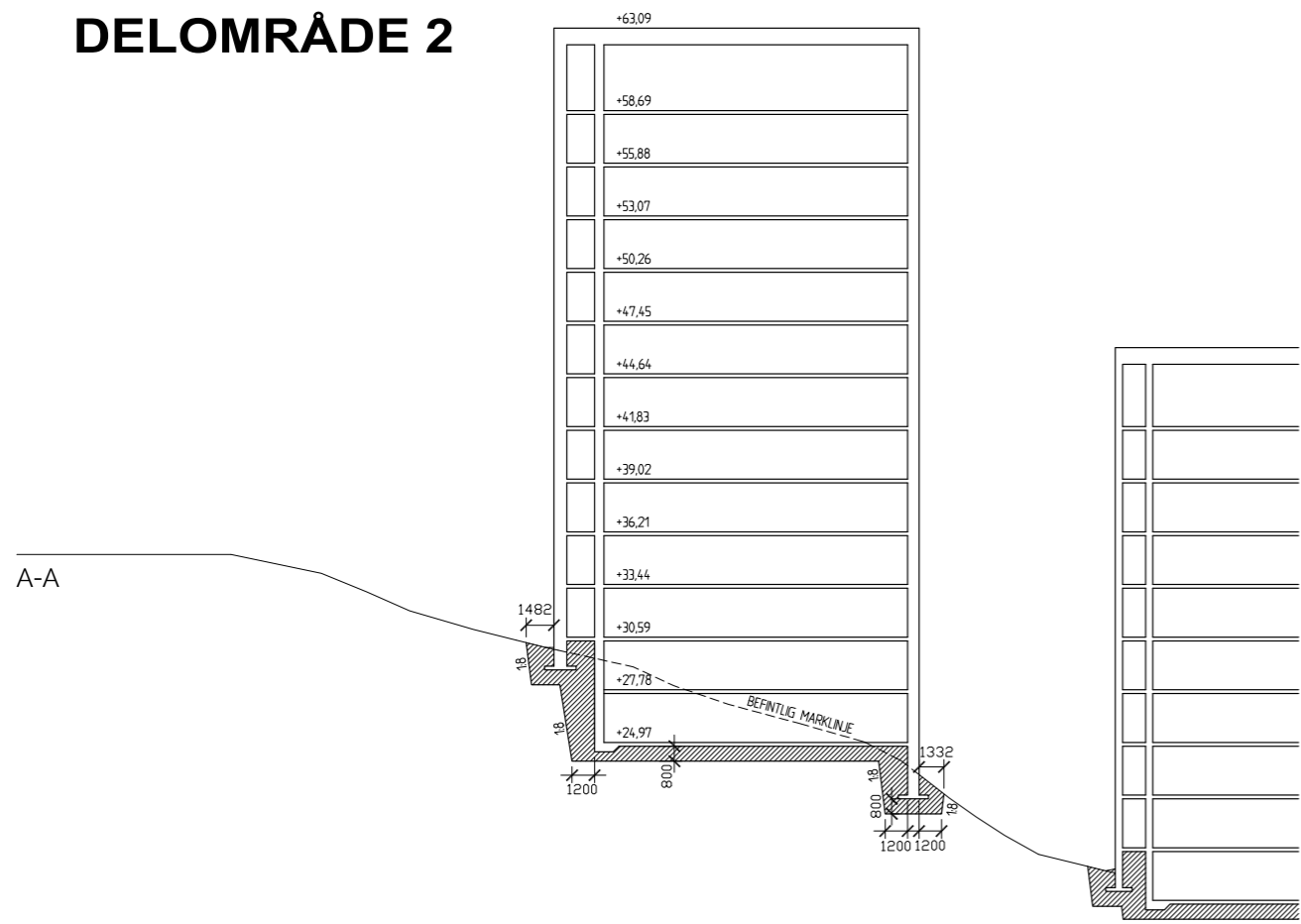

SITUATIONSPLAN UTSNITT

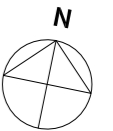

Nacka Strand hus 14
 Carlyle Group
 2015-06-26
 Sprängning höghus
 Skala 1:400

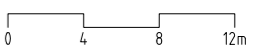

Joliark

DELOMRÅDE 7

SEKTIONER/FASADER

1:200

SEKTION A-A
GENOM
GATA
MOT PARK

